

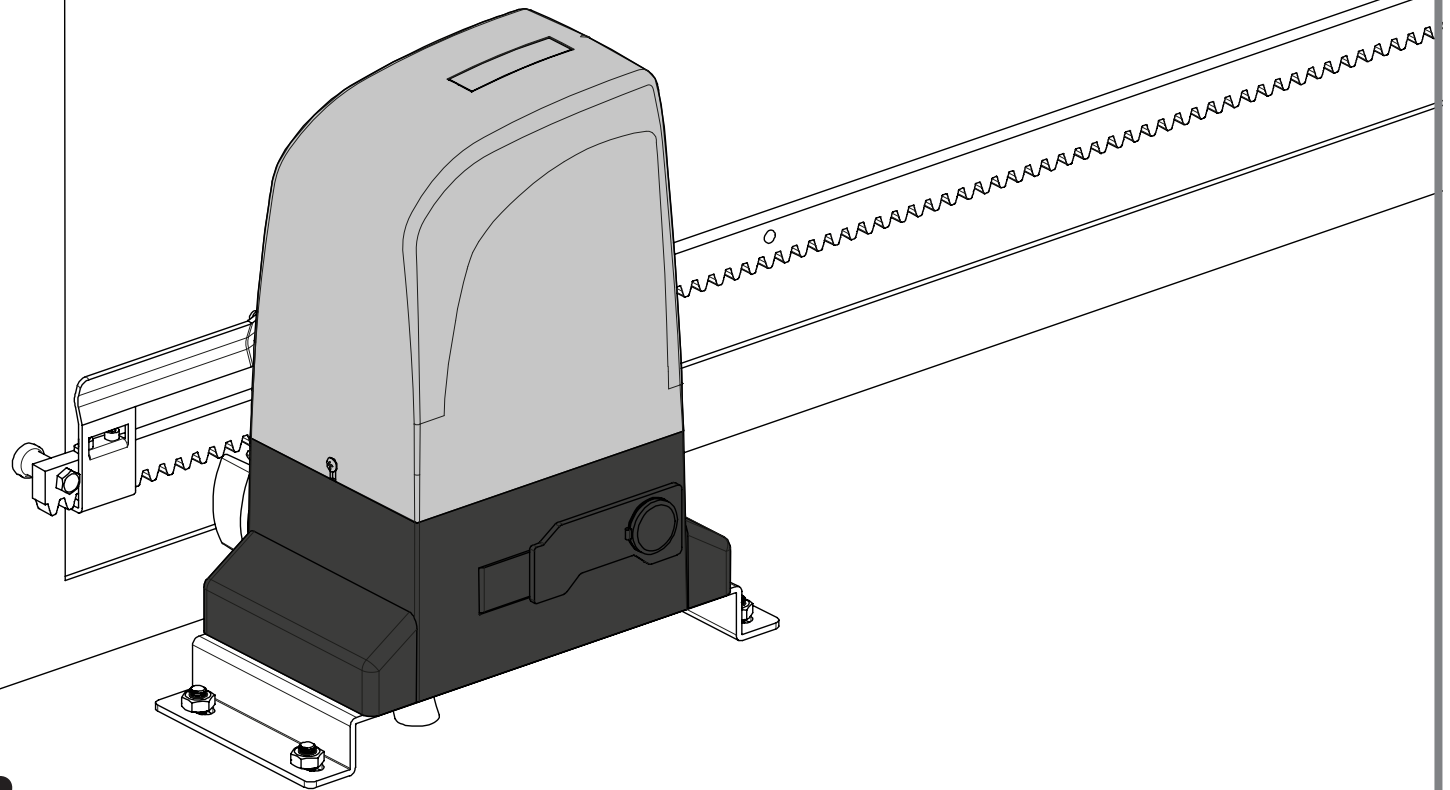

SLIDE & OL

USER'S AND INSTALLER'S MANUAL



motorline[®]
PROFESSIONAL









00. CONTENT

INDEX

01. SAFETY INSTRUCTIONS	1B
02. PACKAGE	
INSIDE PACKAGE	4A
03. OPERATOR	
OPEN COVER	4B
UNLOCK OPERATOR	5A
TECHNICAL SPECIFICATIONS	5B
DIMENSIONS	5B
04. INSTALLATION	
PRELIMINARY CHECKS	6A
SITE INSTALLATION – CREATE FOUNDATION	6A
SITE INSTALLATION – EXISTING FOUNDATION	7A
APPLICATION OF MOTOR	7B
INSTALLATION OF STEEL GEAR RACK	8A
INSTALLATION OF NYLON GEAR RACK	9A
INSTALLATION OF PLATES THE LIMIT SWITCHES	10A
CLUTCH ADJUSTMENT	10B
MAP OF INSTALLATION	11
05. CONNECTIONS OF THE MOTOR	
FOR 800A/OL1500	12A
FOR OL2000	12B
06. TROUBLESHOOTING	
FINAL CONSUMERS INSTRUCTIONS	13
SPECIALIZED TECHNICIANS INSTRUCTIONS	13
07. COMPONENTS TEST	
SCHEMES FOR CAPACITORS	14A
08. MAINTENANCE	
MAINTENANCE	14B

01. SAFETY INSTRUCTIONS

	This product is certified in accordance with European Community (EC) safety standards.
	This product complies with Directive 2011/65/EU of the European Parliament and of the Council, of 8 June 2011, on the restriction of the use of certain hazardous substances in electrical and electronic equipment and with Delegated Directive (EU) 2015/863 from Commission.
	(Applicable in countries with recycling systems). This marking on the product or literature indicates that the product and electronic accessories (eg. Charger, USB cable, electronic material, controls, etc.) should not be disposed of as other household waste at the end of its useful life. To avoid possible harm to the environment or human health resulting from the uncontrolled disposal of waste, separate these items from other types of waste and recycle them responsibly to promote the sustainable reuse of material resources. Home users should contact the dealer where they purchased this product or the National Environment Agency for details on where and how they can take these items for environmentally safe recycling. Business users should contact their vendor and check the terms and conditions of the purchase agreement. This product and its electronic accessories should not be mixed with other commercial waste.
	This marking indicates that batteries should not be discarded like other household waste at the end of their useful life. Batteries must be delivered to selective collection points for recycling.
	The different types of packaging (cardboard, plastic, etc.) must be subject to selective collection for recycling. Separate packaging and recycle it responsibly.
	This marking indicates that the product and electronic accessories (eg. charger, USB cable, electronic material, controls, etc.) are susceptible to electric shock by direct or indirect contact with electricity. Be cautious when handling the product and observe all safety procedures in this manual.

01. SAFETY INSTRUCTIONS

GENERAL WARNINGS

- This manual contains very important safety and usage information. Read all instructions carefully before beginning the installation/usage procedures and keep this manual in a safe place that it can be consulted whenever necessary.
- This product is intended for use only as described in this manual. Any other enforcement or operation that is not mentioned is expressly prohibited, as it may damage the product and put people at risk causing serious injuries.
- This manual is intended firstly for specialized technicians, and does not invalidate the user's responsibility to read the "User Norms" section in order to ensure the correct functioning of the product.
- The installation and repair of this product may be done by qualified and specialized technicians, to assure every procedure are carried out in accordance with applicable rules and norms. Nonprofessional and inexperienced users are expressly prohibited of taking any action, unless explicitly requested by specialized technicians to do so.
- Installations must be frequently inspected for unbalance and the wear signals of the cables, springs, hinges, wheels, supports and other mechanical assembly parts.
- Do not use the product if it is necessary repair or adjustment is required.
- When performing maintenance, cleaning and replacement of parts, the product must be disconnected from power supply. Also including any operation that requires opening the product cover.
- The use, cleaning and maintenance of this product may be carried out by any persons aged eight years old and over and persons whose physical, sensorial or mental capacities are lower, or by persons without any knowledge of the product, provided that these are supervision and instructions given by persons with experienced in terms of usage of the product in a safe manner and who understands the risks and dangers involved.

01. SAFETY INSTRUCTIONS

WARNINGS FOR TECHNICIANS

- Children shouldn't play with the product or opening devices to avoid the motorized door or gate from being triggered involuntarily.
- If the power cable is damaged, it must be replaced by the manufacturer, after-sales service or similarly qualified personnel to avoid danger.
- The device must be disconnected from the electrical network when removing the battery.
- Ensure that blocking is avoided between the actuated part and its fixed parts due to the opening movement of the actuated part.

- Before beginning the installation procedures, make sure that you have all the devices and materials necessary to complete the installation of the product.
- You should note your Protection Index (IP) and operating temperature to ensure that is suitable for the installation site.
- Provide the manual of the product to the user and let them know how to handle it in an emergency.
- If the automatism is installed on a gate with a pedestrian door, a door locking mechanism must be installed while the gate is in motion.
- Do not install the product "upside down" or supported by elements do not support its weight. If necessary, add brackets at strategic points to ensure the safety of the automatism.
- Do not install the product in explosive site.
- Safety devices must protect the possible crushing, cutting, transport and danger areas of the motorized door or gate.
- Verify that the elements to be automated (gates, door, windows, blinds, etc.) are in perfect function, aligned and level. Also verify if the necessary mechanical stops are in the appropriate places.
- The control board must be installed on a safe place of any fluid (rain, moisture, etc.), dust and pests.
- You must route the various electrical cables through protective tubes, to protect them against mechanical exertions, essentially on

01. SAFETY INSTRUCTIONS

the power supply cable. Please note that all the cables must enter the control board from the bottom.

- If the automatism is to be installed at a height of more than 2,5m from the ground or other level of access, the minimum safety and health requirements for the use of work equipment workers at the work of Directive 2009/104/CE of European Parliament and of the Council of 16 September 2009.
- Attach the permanent label for the manual release as close as possible to the release mechanism.
- Disconnect means, such as a switch or circuit breaker on the electrical panel, must be provided on the product's fixed power supply leads in accordance with the installation rules.
- If the product to be installed requires power supply of 230Vac or 110Vac, ensure that connection is to an electrical panel with ground connection.
- The product is only powered by low voltage safety with control board (only at 24V motors).
- Parts/products weighing more than 20 kg must be handled with special care due to the risk of injury. It is recommended to use suitable auxiliary systems for moving or lifting heavy objects.
- Pay special attention to the danger of falling objects or uncontrolled movement of doors/gates during the installation or operation of this product.

WARNINGS FOR USERS

- Keep this manual in a safe place to be consulted whenever necessary.
- If the product has contact with fluids without being prepared, it must immediately disconnect from the power supply to avoid short circuits, and consult a specialized technician.
- Ensure that technician has provided you the product manual and informed you how to handle the product in an emergency.
- If the system requires any repair or modification, unlock the automatism, turn off the power and do not use it until all safety

01. SAFETY INSTRUCTIONS

conditions have been met.

- In the event of tripping of circuits breakers or fuse failure, locate the malfunction and solve it before resetting the circuit breaker or replacing the fuse. If the malfunction is not repairable by consult this manual, contact a technician.
- Keep the operation area of the motorized gate free while the gate in in motion, and do not create strength to the gate movement.
- Do not perform any operation on mechanical elements or hinges if the product is in motion.

RESPONSABILITY

- Supplier disclaims any liability if:
 - Product failure or deformation result from improper installation use or maintenance!
 - Safety norms are not followed in the installation, use and maintenance of the product.
 - Instructions in this manual are not followed.
 - Damaged is caused by unauthorized modifications
 - In these cases, the warranty is voided.

MOTORLINE ELECTROCELOS SA.

Travessa do Sobreiro, nº29
4755-474 Rio Côvo (Santa Eugénia)
Barcelos, Portugal

SYMBOLS LEGEND:



• Important safety notices



• Useful information



• Programming information



• Potentiometer information



• Connectors information



• Buttons information

02. PACKAGE

INSIDE PACKAGE

Inside the package you will find the following components:

- 01• 01 motor
- 02• 02 release keys
- 03• 04 screws DIN912 M5x10
- 04• 04 fixing screws to the plate
- 05• 04 fixing screws to the ground
- 06• 01 fixation plate
- 07• 02 fixation plate of the limit switches
- 08• 01 user's manual
- 09• 02 photocells
- 10• 02 remote controls
- 11• 01 Control board

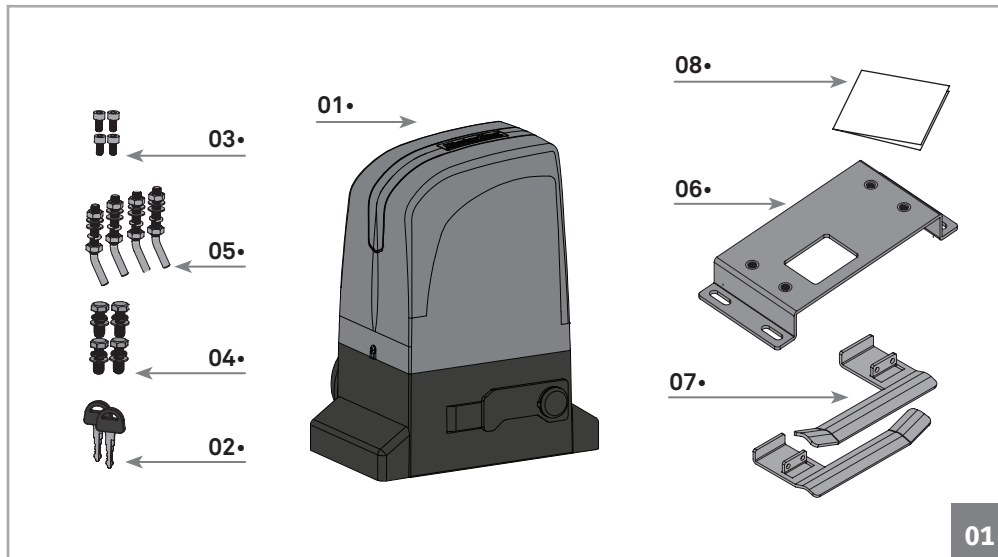

Electronic components of the kit:

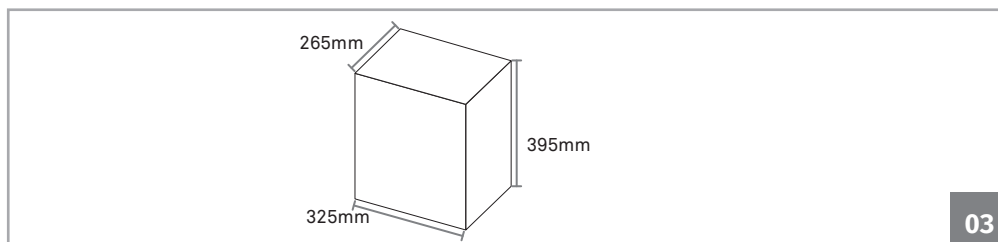

03. OPERATOR

OPEN COVER

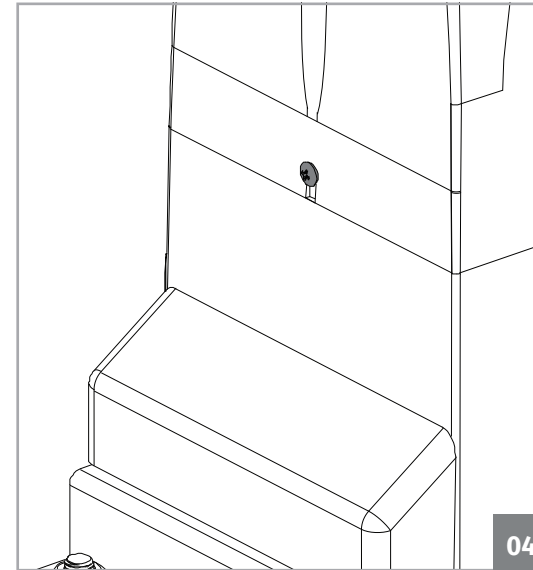

During installation you will need to open the motor cover, to access various components on the inside. For this, loosen the 2 screws identified with (A) until the cover is free to be removed.

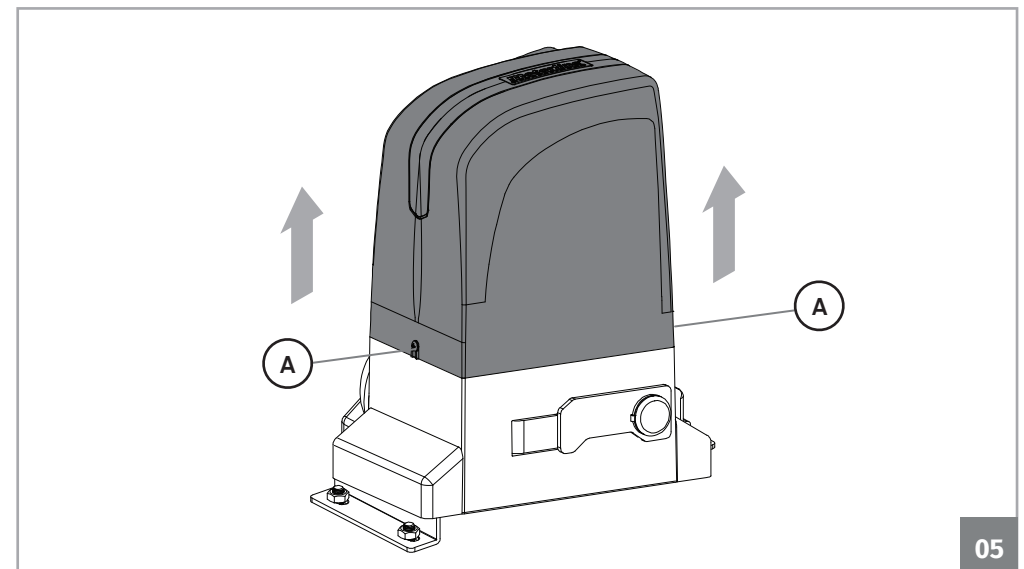

03. OPERATOR

UNLOCK OPERATOR

To open manually the gate in case of electric power failure or in case of damage, follow the below steps:

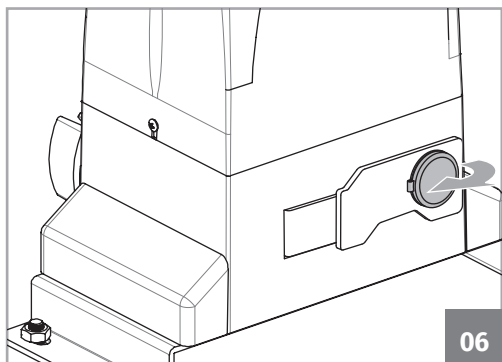

06

01 • Open the protection cover to access the key hole for the release.

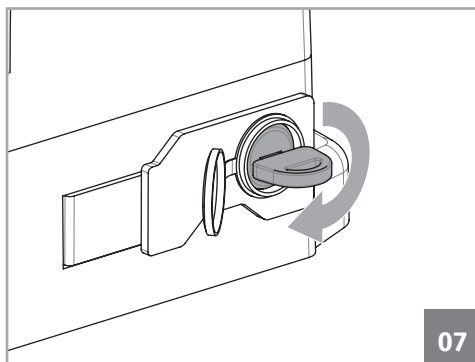

07

02 • Insert the key and turn it 90°.

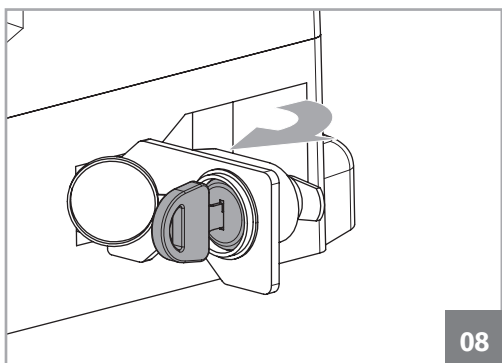

08

03 • Pull the lever towards the outside, and you can now open/close the gate manually.

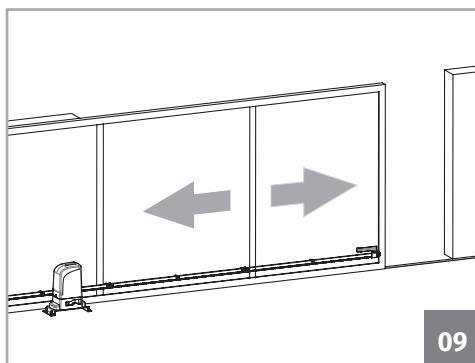

09

So that the automation will operate normally, close the unlock and turn the key to the original position. Close the cover (06) to finish, make a move in order to confirm the functioning of the automation.

03. OPERATOR

TECHNICAL SPECIFICATIONS

Technical specifications of the automated operator:

	800A		OL1500		OL2000	
	110V	230V	110V	230V	110V	230V
• Power supply	110V, 60Hz	230V, 50Hz	110V, 60Hz	230V, 50Hz	110V, 60Hz	230V, 50Hz
• Rated absorbed power	370W		550W		1000W	
• Max speed	186mm/snd		186mm/snd		186mm/snd	
• Noise	≤ 56dB		≤ 56dB		≤ 56dB	
• Operating temperature	>-25°C, <65°C		>-25°C, <65°C		>-25°C, <65°C	
• Protection class	IP44		IP44		IP44	
• Thermal protection (°C)	120°C		120°C		120°C	
• Leaf max weight (Kg)	800Kg		1500Kg		2000Kg	
• Working frequency	40%		70%		70%	
• Capacitor	35µF	12uF	60µF	16uF	25µF and 70µF	12,5uF and 25uF

DIMENSIONS

The dimensions (mm) of automatism are the following:

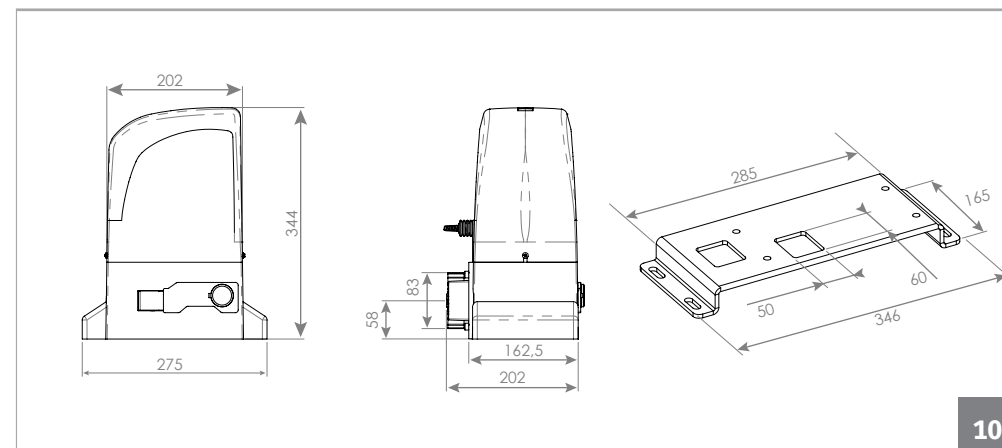

10

04. INSTALLATION

PRELIMINARY CHECKS



To ensure safety and an efficiently operating automated system, make sure the following conditions are applied:

- The structure of the gate must be suitable for being automated. In particular, check that the structure is sufficiently strong and rigid, and that its dimensions and weight conform to those indicated in the technical specifications;
- Make sure that the gate slides without any inclination;
- Make sure that the gate moves uniformly and correctly, without any irregular friction during its entire travel;
- The soil must permit sufficient stability for the expansion plugs securing the foundation plate;
- Remove any locks and lock bolts. We advise you to have any metalwork carried out before the automated system is installed.

INSTALLATION SITE PREPARATION

NOTE:

For correct operation of the automatism, it is necessary to pay attention to the dimensions given in the following images. Also check that the fixation plate is parallel to the gate.

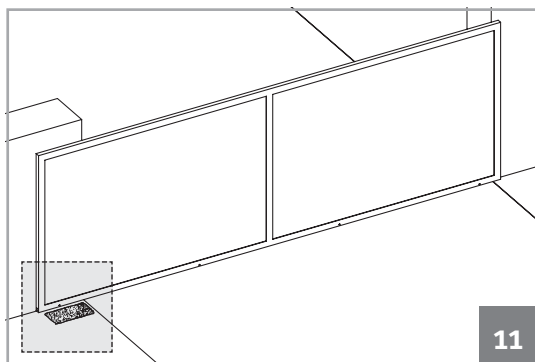

11

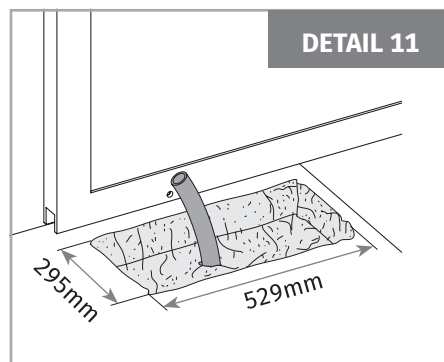

DETAIL 11

01 • Make a hole in the ground to create a foundation in concrete. The dimensions shown are these recommended to create the foundation. You must leave tubes in the middle of the hole for the passage of cables for power and accessories, as shown in the detail of image 11.

04. INSTALLATION

SITE INSTALLATION – CREATE FOUNDATION

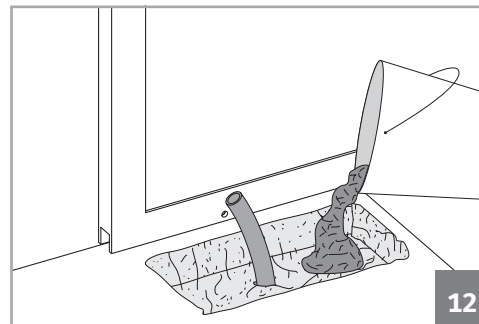

12

02 • Fill the hole with fresh concrete and smooth the top part where you will fix the plate.

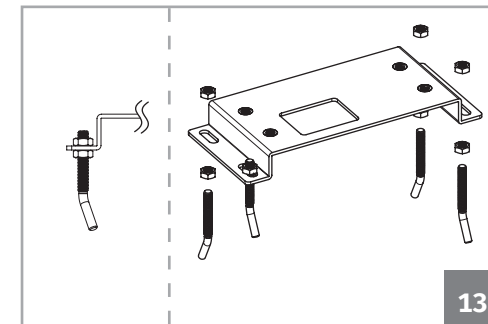

13

03 • Attach the screws to the plate with nut and counter nut as shown in picture 13.

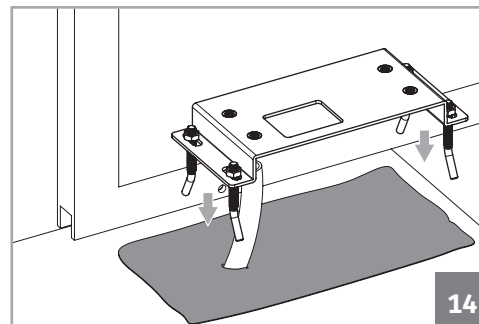

14

04 • Insert the plate with screws in the concrete while it is still fresh and level it horizontally with a level. Also align it parallel to the gate, keeping a distance of 60mm between them, as visible in picture 16.

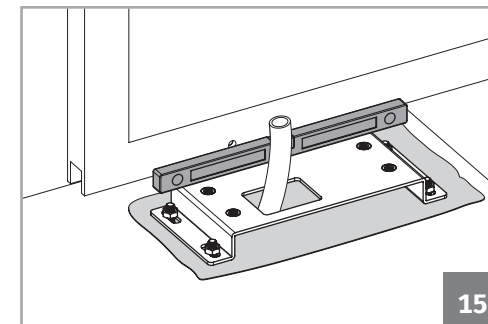

15

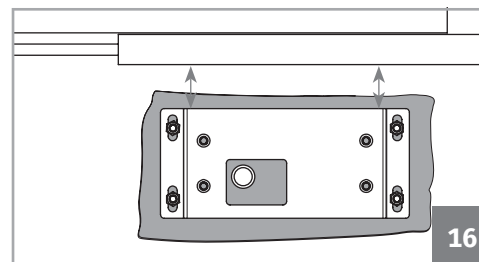

16

05 • Let the concrete dry so that the plate stays well fixed.

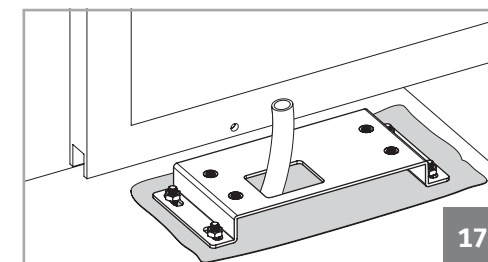

17

04. INSTALLATION

SITE INSTALLATION – EXISTING FOUNDATION

In case there is already a foundation at the installation site, proceed as below:

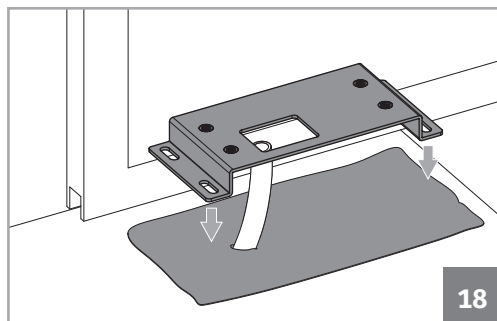

18

01 • Place the fixing plate on top of the foundation and align it parallel to the gate, keeping a distance of 60mm between them, as visible in Figure 19.

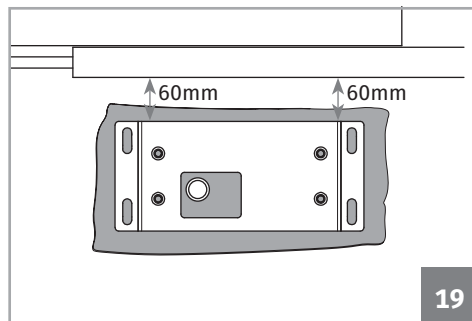

19

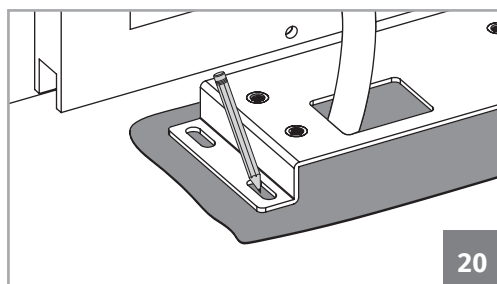

20

02 • Mark the place to make the holes for the bushings. Must make the mark at the center of the oval holes of the plate.

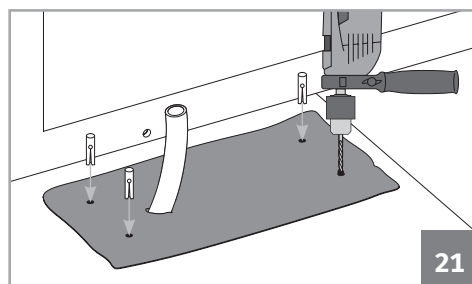

21

03 • Drill four holes with $\varnothing 18\text{mm}$ on foundation. Place M10 steel anchors on the holes.

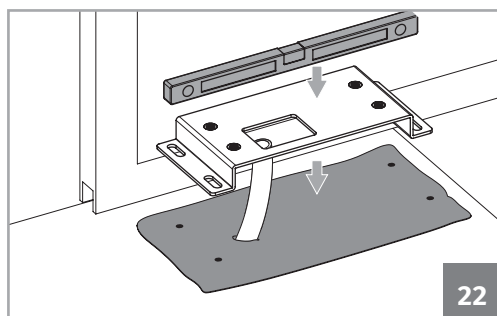

22

04 • Place the fixing plate on the foundation in cement respecting the distances of image 19. Use a level to level it horizontally and fasten it with M10 screws.

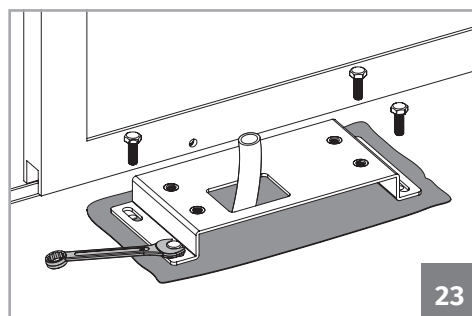

23

04. INSTALLATION

APPLICATION OF MOTOR

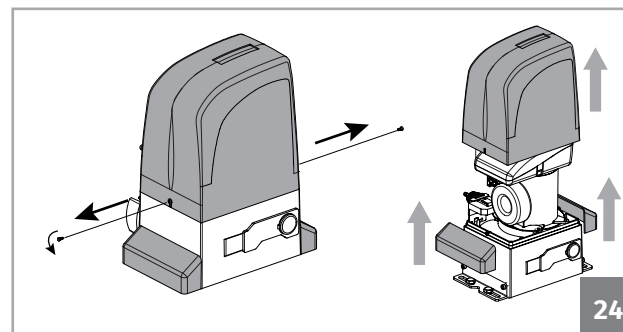

24

01 • Remove the motor covers (following the steps on page 4B), and the side covers.

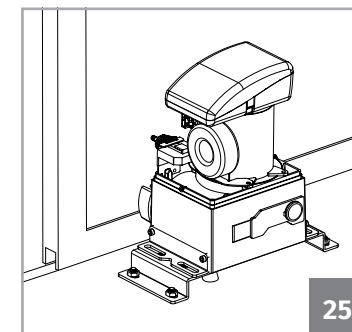

25

02 • Place the motor in the fixing plate.

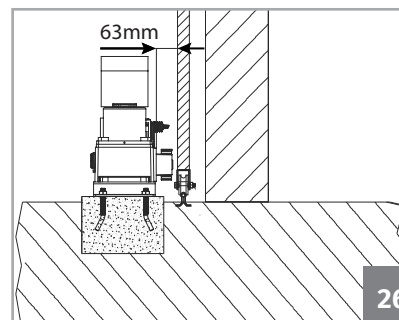

26

03 • Align it parallel to the gate leaving a distance of 63mm between them, as visible in the image 26. Oval holes of the motor should be centered with the threaded holes in the fixing plate, as visible on DETAIL 26.

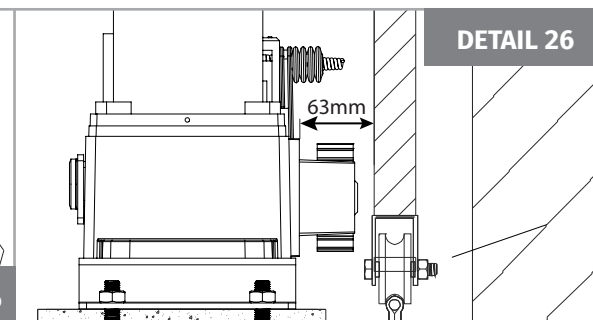

DETAIL 26

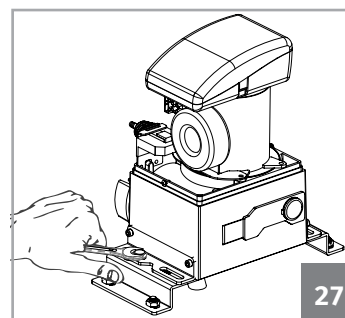

27

04 • Fix it with the M10 x 25 screws provided.

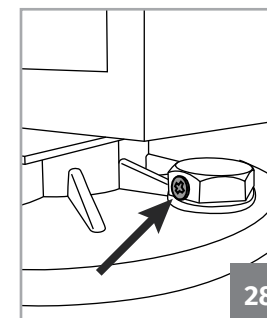

28

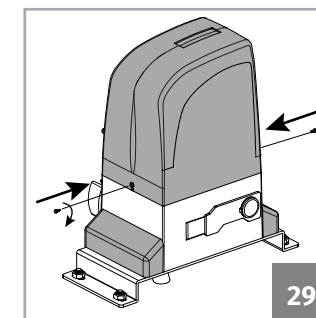

29



Before you close again the covers, remove the breath screw (**applicable only in OL1500 and OL2000**)

04. INSTALLATION

INSTALLATION OF STEEL GEAR RACK



Place the gate in the open position and unlock the motor! (p.05A.)

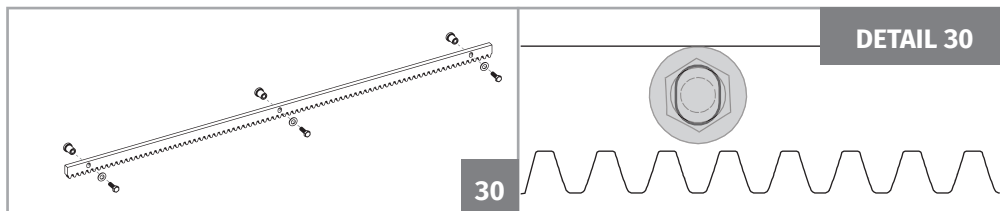

01 • Place spacers in all holes of the rack to fix it to the gate. Must put them in the center of the oval holes in the rack, as shown in Figure 30, so you can adjust the rack at the end of the installation if necessary.

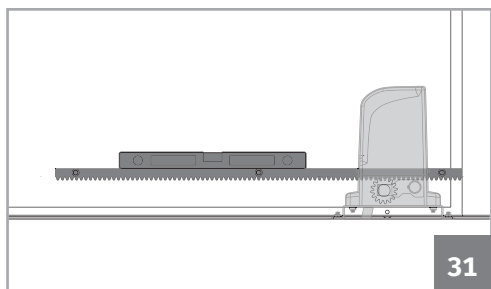

02 • Place a piece of rack on top of the pinion and level it horizontally with a level.

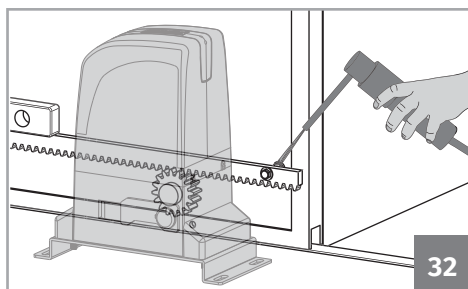

03 • Weld the spacer on top of the pinion.

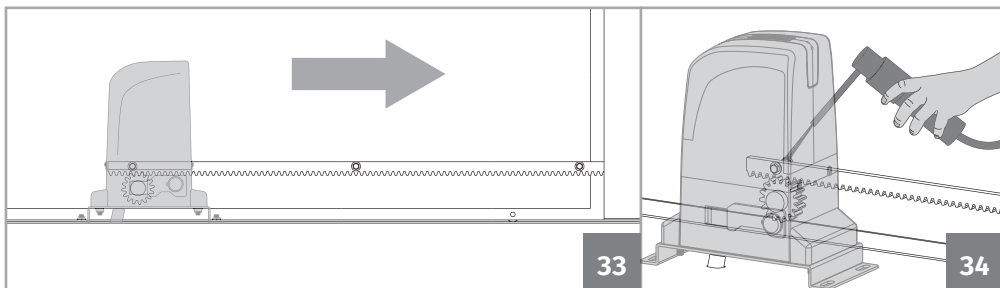

04 • Close the gate a bit until the other end of the rack rests on top of the pinion and weld the other spacer to the gate.

04. INSTALLATION

INSTALLATION OF STEEL GEAR RACK

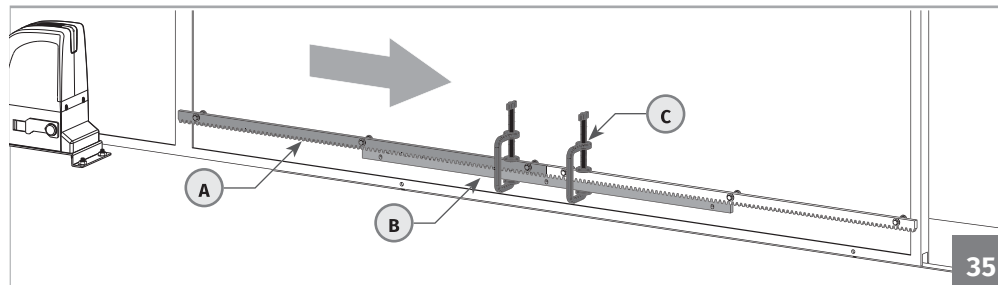

05 • Close the gate a bit, so that the rack is not being supported on the pinion anymore and apply another piece of rack (A). To synchronize the teeth with the piece already installed, use an additional piece of rack (B) and place it under the union of the other two, holding them with clamps (C).

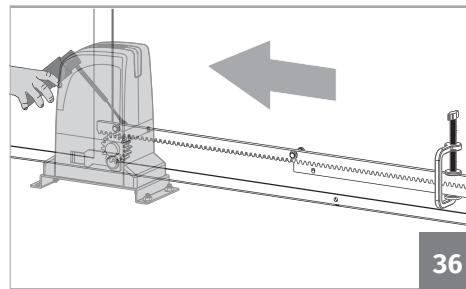

06 • Open the gate to support the point of the new piece of rack on top of the pinion and weld the piece.

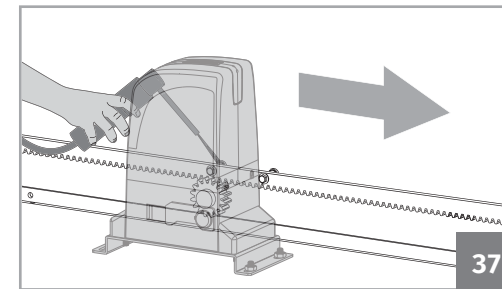

07 • Remove the piece of auxiliary rack and open the gate until the other end of the rack stands on top of the pinion. Weld the spacer.

08 • Repeat the steps 5-7 for each meter of the rack, until you reach the end.

09 • Manually, test the movement of the gate with all racks already installed and weld the remaining spacers. In case of finding some friction between the rack and pinion, adjust the rack on the oval holes with screws.



During the course of the gate, all elements of the rack must mesh properly with the pinion (space 1.5mm)!
The spacers can't be welded to the rack! And also the pieces of rack with one another.
Do not use mass or other types of lubricant between rack and pinion!

04. INSTALLATION

INSTALLATION OF NYLON GEAR RACK



Place the gate in the open position and unlock the motor! (p.05A)

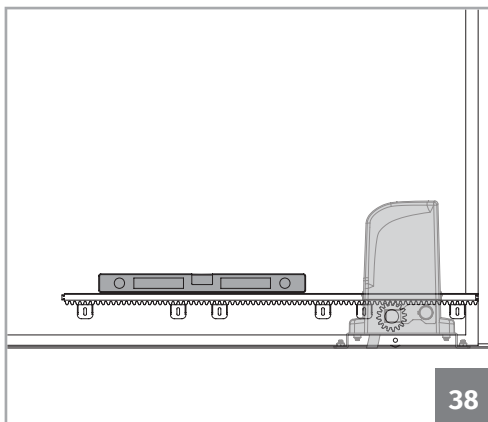

01 • Place a piece of rack on top of the pinion and level it horizontally with a level.

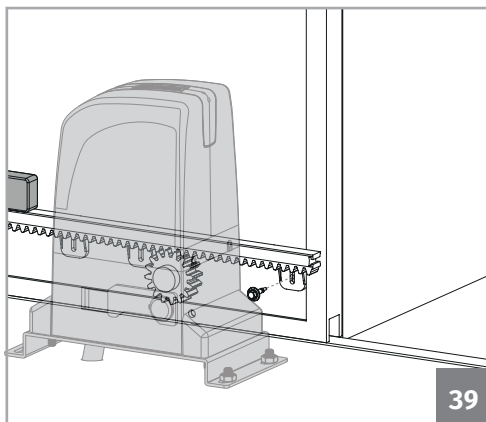

02 • Fasten the support of the rack over the pinion to the gate.

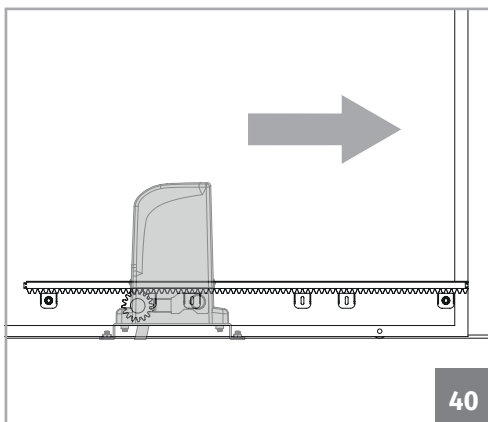

03 • Close the gate a bit until the other end of the rack rests on top of the pinion and fasten the other support.

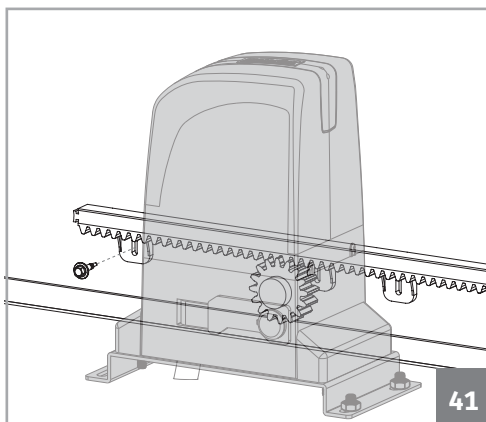

41

04. INSTALLATION

INSTALLATION OF NYLON GEAR RACK

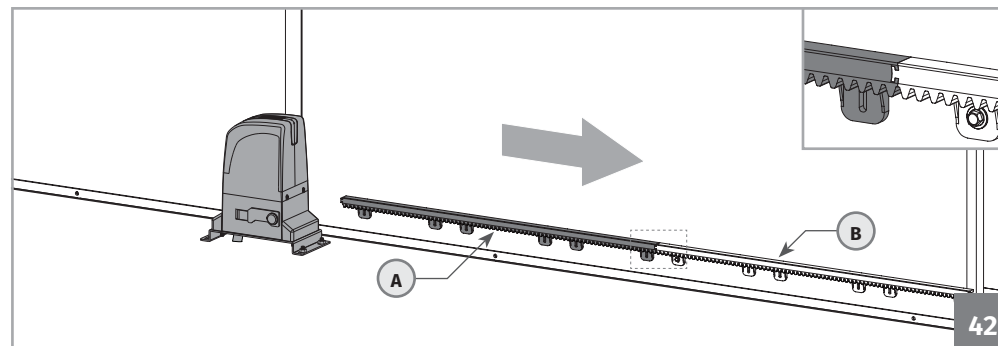

04 • Close the gate a bit, so that the rack is not being supported on the pinion anymore and apply another piece of rack (A), fitting it into the rack already installed (B), as you can see in detail of image 41.

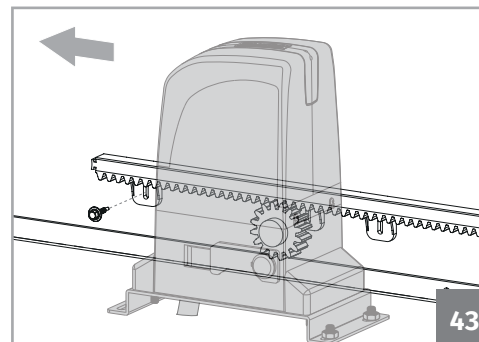

05 • Open the gate until the other end of the new rack is on top of the pinion rack and fasten it to the gate.

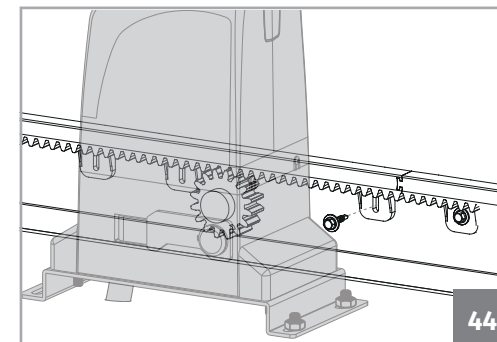

06 • Open the gate until the other end of the rack stands on top of the pinion. Fasten it to the gate.

07 • Repeat the steps 4-6 for each rack piece until you reach the end.



During the course of the gate, all elements of the rack must mesh properly with the pinion!
All rack supports must be welded at the gate.
Do not use mass or other types of lubricant between rack and pinion!

04. INSTALLATION

INSTALLATION OF PLATES THE LIMIT SWITCHES



Place the gate in the open position and unlock the motor! (p.05A)

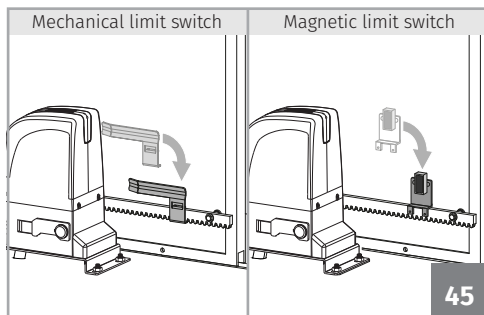

45

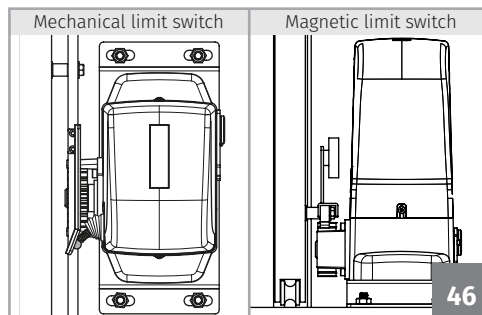

46

01 • Place the opening limit-switch plate in the rack so that it can trigger the limit-switch of the motor before the gate gets to opening stopper. The mechanical limit switch is activated when the plate is in contact with the spring. The magnetic limit switch is activated when the magnet is aligned with the motor reader (Fig. 45).

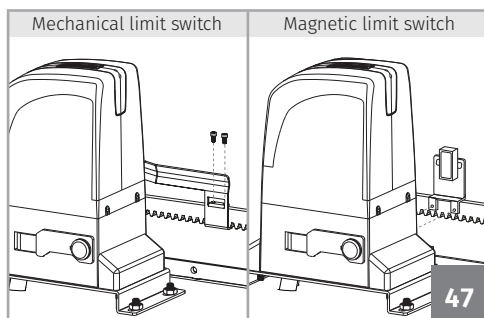

47

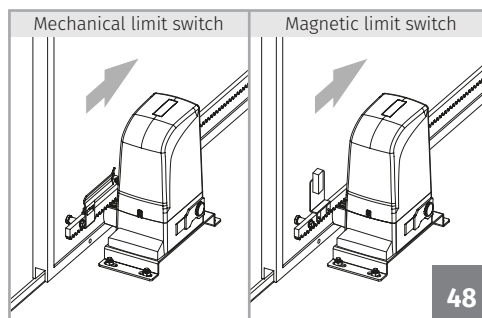

48

02 • Put the DIN912 M5 x 12 screws supplied with the accessories until the limit-switch plate is fixed to the rack.

03 • Move the gate to the closed position and repeat steps 1 and 2 to fix the closing limit-switch plate to the rack.



The limit-switch plates must be tuned for the gate stop before it hits the opening and closing stoppers. Manually test the activation of the limit-switches with the gate unlocked, before you connect it to the electric power, in order to prevent problems due to bad installation.

04. INSTALLATION

CLUTCH ADJUSTMENT



To start the disassembly of the control board, disconnect the power and have maximum care when handling it.

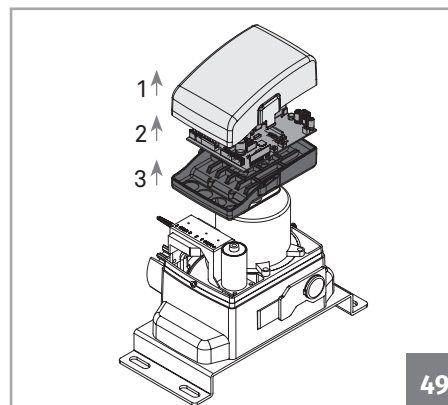

49

01 • Unbolt the screws and remove the cover, as explained in p. 04B.

02 • You must now access the adjusting screw of the clutch.

For this remove the cover of the control board box. Loosen the 2 screws of the control board and remove it from the box. Now loosen the 2 screws that fix the box of control board to the motor and remove it as well.

03 • Adjust the screw in the upper part of the motor. Use a 6mm hexagon key as shown in image 50.

How to make the adjustment:

•Irreversibility of the motor.

Do a test to the motor's irreversibility. For that, just try to move the gate manually with the motor locked. If the gate is moving, it is necessary to adjust the screw by rotating it clockwise (+).

•Idle speed of the motor

If the gate does not move at idle speed, it means that the screw is too much tightened. Rotate it counterclockwise (-) until the motor moves the gate at idle speed.

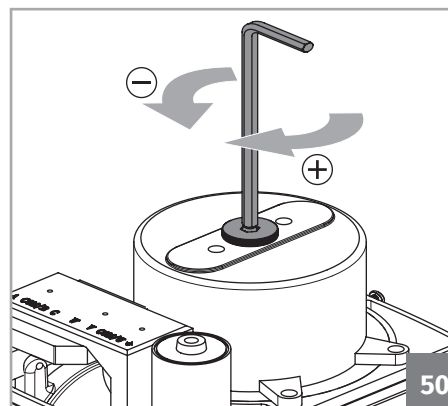

50



The tuning must achieve a balance between the gate's irreversibility and the engines power. Any adjustment must always be made lightly, always experimenting the motor's operation with every adjustment until you achieve the necessary balance between the irreversibility of the motor and the strength of idle speed.

04. INSTALLATION

MAP OF INSTALLATION

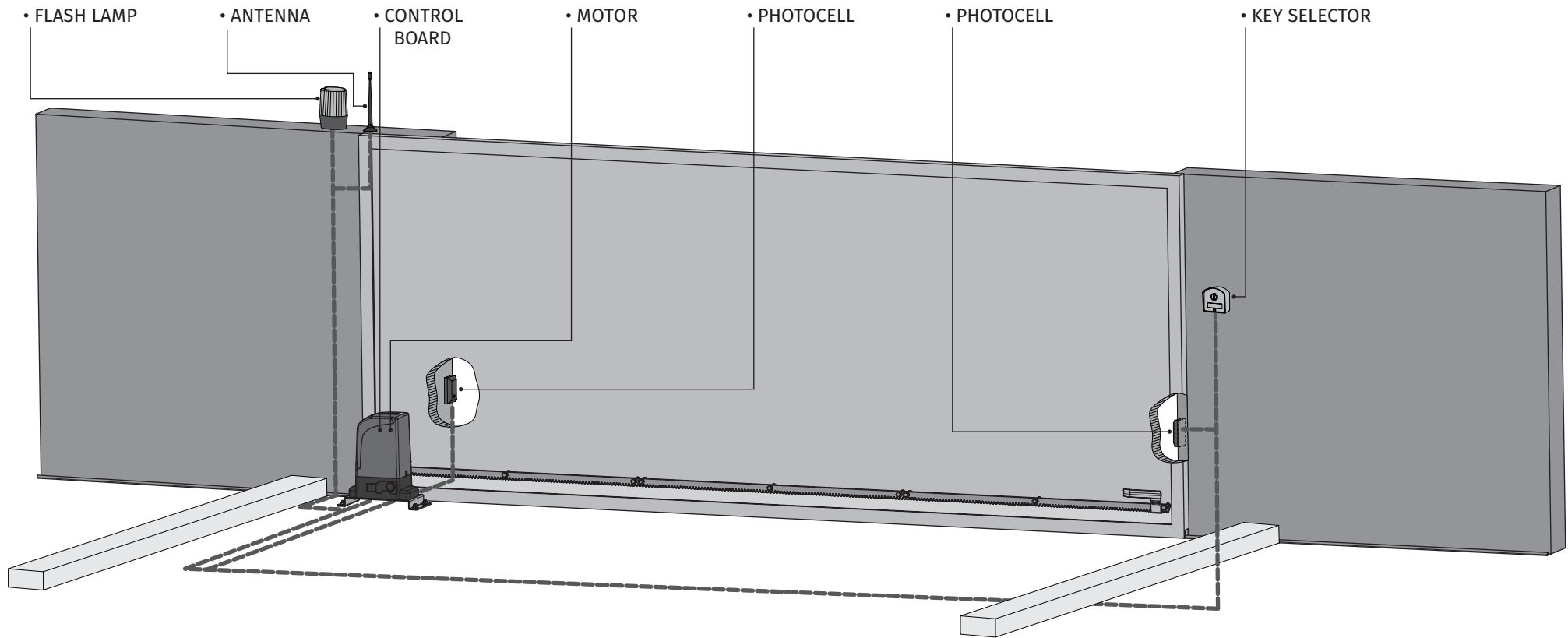

LEGEND:

----- • Cables of connection



It is important to use stoppers on the opening and closing of the gate. If this is not respected, there may be danger of the gate open too much in manual mode and jump out of the rail.



It is important to use junction boxes for connections between motors, components and control board. All cables enter and exit under the junction box and box of control board.

05. CONNECTIONS OF THE MOTOR

FOR 800A/OL1500

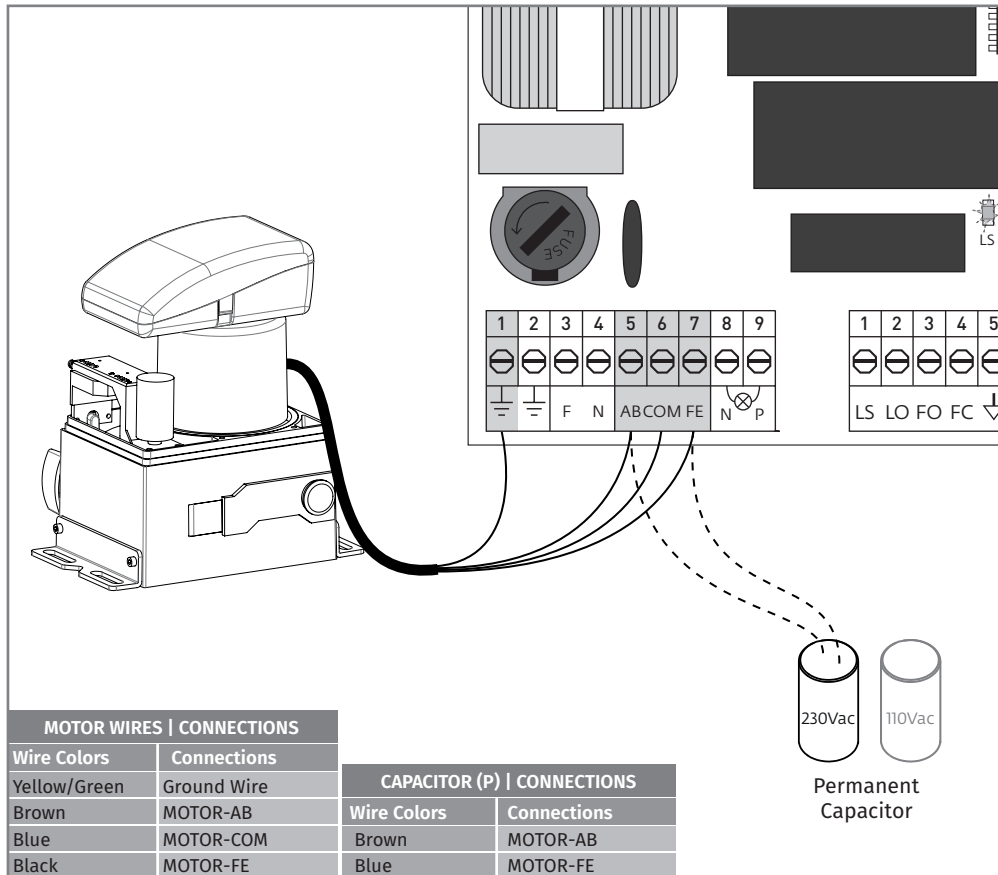

The motor connections must be made as shown above, by connecting the 4 motor wires to the appropriate inputs of the control board.

NOTE: The wires of the permanent capacitor (110Vac or 230Vac) must be connected directly to the control board as shown above.

05. CONNECTIONS OF THE MOTOR

FOR OL2000

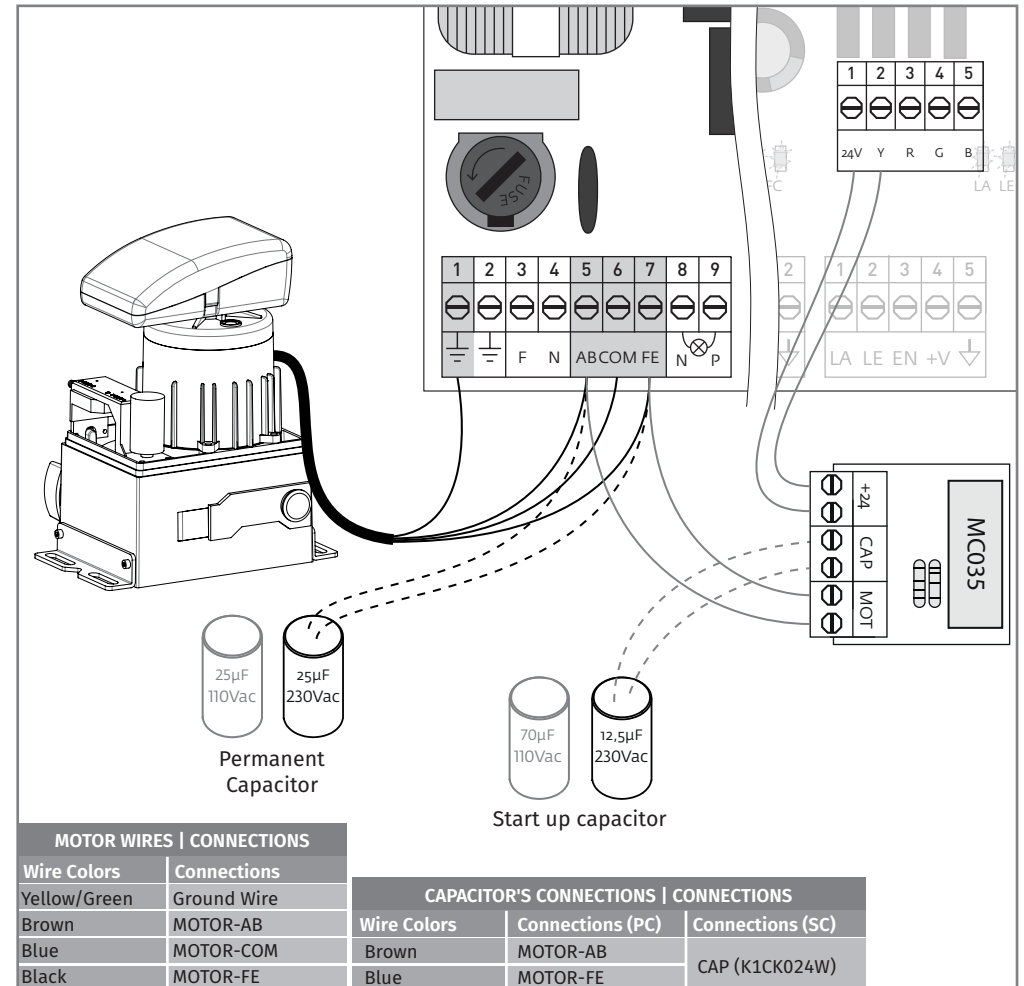

The motor connections must be made as shown above, by connecting the 4 motor wires to the appropriate inputs of the control board.

NOTE: In this motor you must use two capacitors, one of which works permanently and the other only works during the start up.

With 230Vac use 12.5uF + 25uF, and with 110Vac use 25uF + 70uF, connected as in the scheme above.

06. TROUBLESHOOTING

FINAL CONSUMERS INSTRUCTIONS

SPECIALIZED TECHNICIANS INSTRUCTIONS

Problem	Procedure	Behavior	Procedure II	Discovering the origin of the problem			
• Motor doesn't work	• Make sure you have 230V power supply connected to control board and if it is working properly.	• Still not working	• Consult a qualified MOTORLINE technician.	1 • Open control board and check if it has 230V power supply; 2 • Check input fuses of the control board;	3 • Disconnect the motor from control board and test them by connecting directly to power supply in order to find out if they have problems (see page 11A).	4 • If the motor works, problem is on the control board. Pull it out and send it to our MOTORLINE technical services for diagnosis;	5 • If the motor doesn't work, remove them from installation site and send to our MOTORLINE technical services for diagnosis.
• Motor doesn't move but makes noise	• Unlock motor and move the gate by hand to check for mechanical problems on the movement.	• Encountered problems?	• Consult a qualified gates technician.	1 • Check motion axis and associated motion systems related with the motor and the gate to find out what is the problem.			
		• The gate moves easily?	• Consult a qualified MOTORLINE technician.	1 • Check capacitor, testing operator with a new one;	2 • If capacitors are not the problem, disconnect motor from control board and it them by connecting directly to power supply in order to find out if it has problems (see page 11A);	3 • If the motor works, the problem is from control board. Pull it out and send it to our MOTORLINE technical services for diagnosis;	4 • If the motor doesn't work, remove them from installation site and send to our MOTORLINE technical services for diagnosis.
• Motor opens but doesn't close	• Unlock motor and move the gate by hand to closed position. Lock motor again and turn of power supply for 5 seconds. Reconnect it and send order to open gate using transmitter.	• Gate opened but didn't close again..	1 • Check if there is any obstacle in front of the photocells; 2 • Check if any of the control devices (key selector, push button, video intercom, etc.) of the gate are jammed and sending permanent signal to control unit; 3 • Consult a qualified MOTORLINE technician.	All MOTORLINE control boards have LEDs that easily allow to conclude which devices are with anomalies. All safety devices LEDs (DS) in normal situations remain On. All "START" circuits LEDs in normal situations remain Off If LEDs devices are not all On, there is some security systems malfunction (photocells, safety edges), etc. If "START" circuits LEDs are turn On, there is a control device sending permanent signal	A) SECURITY SYSTEMS: 1 • Close with a shunt all safety systems on the control board (check manual of the control board in question). If the automated system starts working normally check for the problematic device. 2 • Remove one shunt at a time until you find the malfunction device. 3 • Replace it for a functional device and check if the motor works correctly with all the other devices. If you find another one defective, follow the same steps until you find all the problems.	B) START SYSTEMS: 1 • Disconnect all wires from START terminal input. 2 • If the LED turned Off, try reconnecting one device at a time until you find the defective device. NOTE: In case procedures described in sections A) and B) don't result, remove control board and send to our technical services for diagnosis;	
• Gate doesn't make complete route	• Unlock motor and move gate by hand to check for mechanical problems on the gate.	• Encountered problems?	• Consult a qualified gates technician.	1 • Check all motion axis and associated motion systems related with the gate to find out what is the problem.			
		• The gate moves easily?	• Consult a qualified MOTORLINE technician.	1 • Check capacitors, testing with new capacitors. 2 • If capacitors are not the problem, disconnect motor from control board and test it by connecting directly to power supply in order to find out if it is broken;	3 • f the motor doesn't work, remove it from installation site and send to our MOTORLINE technical services for diagnosis. 4 • If motor work well and move gate at full force during the entire course, the problem is from controller. Set force using trimmer on the board. Make a new working time programming, giving sufficient time for opening and closing with appropriate force .	5 • If this doesn't work, remove control unit and send it to MOTORLINE technical services.	NOTE: Setting force of the controller should be sufficient to make the gate open and close without stopping, but should stop and invert with a little effort from a person. In case of safety systems failure, the gate shall never cause physical damaged to obstacles (vehicles, people, etc).

07. COMPONENTS TEST

SCHEMES FOR CAPACITORS

To detect if the malfunction is on the control board or on the motor is, sometimes, necessary to perform tests with connection directly to a 110V/230V power supply.

For this, it is necessary to interpose a capacitor in the connection in order to the automatism to work (check the type of capacitor to be used in the product manual). The diagram below, shows how to make that connection and how to merge the different components wires.

NOTES:

- > To perform the tests, there is no need to remove the automatism from the place it is installed, because in this way, it is possible to understand if the automatism can function properly connected directly to the current.
- > You should use a new capacitor during this test to ensure that the problem does not lie on it.

- 01** • Connect the power wires to the terminal, as shown below.
- 02** • Connect the automatism wires in the terminal, interposing a capacitor in the opening and closing wires.
- 03** • Once these connections are completed, connect to a 110V/230V power outlet, depending on the motor / control board in test.

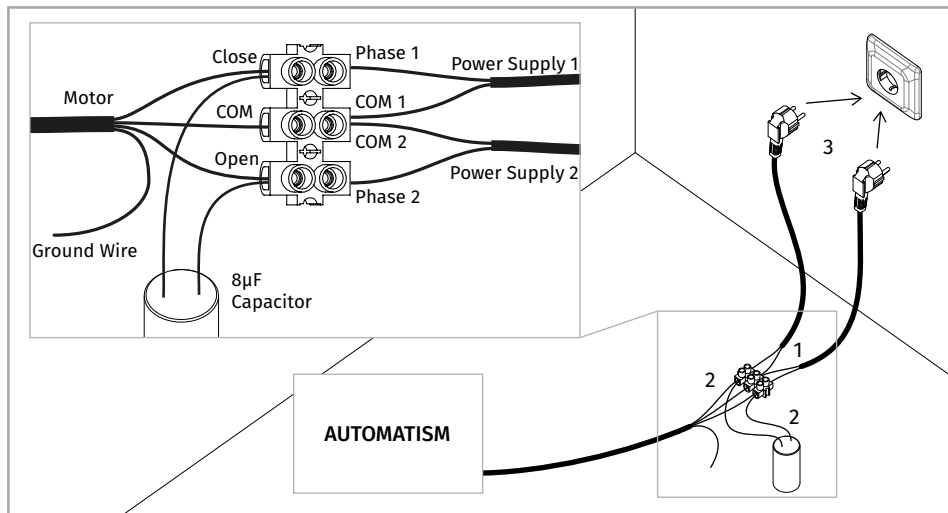

08. MAINTENANCE

MAINTENANCE

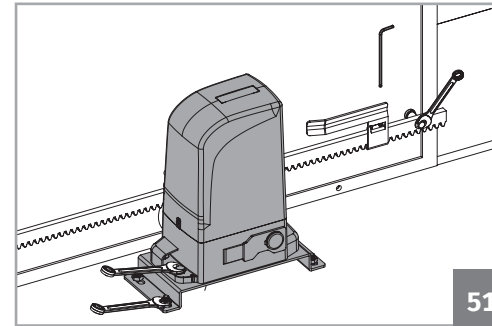

- Check all screws of the automation such as the fixing plate to the ground, the plates of the limit switches, motor and the gear rack.

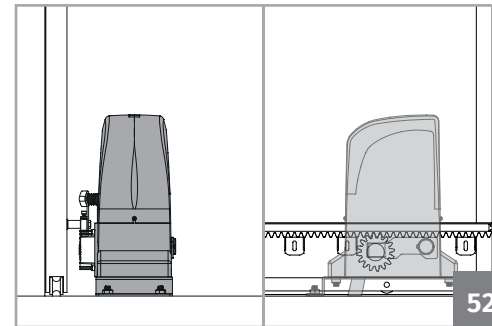

- Check that the distance between rack and motor remains unchanged and this engages the teeth of the pinion of the engine correctly (over time can happen some distortion).

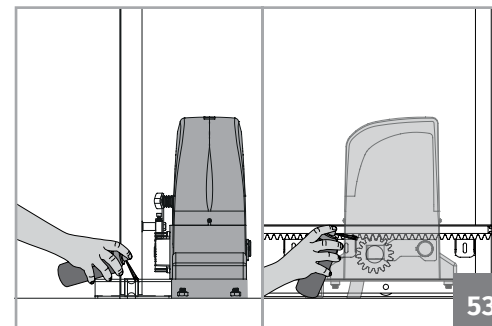

- Lubricate all systems/axis of movement of the gate. Lightly lubricate with spray the rack and pinion.



All tests must be performed by skilled technicians due to serious danger associated with the misuse of electrical systems!!



These maintenance measures must be made every 6 months to maintain the good functioning of the automatism.